



# **OPERATING MANUAL FLARM COLLISION WARNING UNIT**

Status  
Software Version 3.00 (February 13, 2006)

© 2003-2006 FLARM Technology GmbH  
Zurich-Switzerland  
[www.flarm.com](http://www.flarm.com)  
[info@flarm.com](mailto:info@flarm.com)

## **1. Welcome to the FLARM user community**

Thank you for purchasing FLARM, a modern low-cost collision-warning unit for sailplanes and light aircraft. The main task for FLARM is to support the pilot, while he scans the airspace ahead with his own eyes. FLARM is simple to use and does not distract the pilot from the main business in hand.

 Sport flying is an activity that is associated with considerable risks for crew, passengers, third parties and other objects. **In order to make full and safe use of FLARM, it is absolutely essential to be fully aware of the risks, operating conditions, restrictions and limitations associated with the use of FLARM. This includes familiarity with and observance of this Operating Manual and the Installation Manual.** Additional configuration information can be found in the 'Data Port Specifications' document.

We welcome user feedback and reports, suggestions for improvements, and pictures that will help us make further improvements to FLARM. Feedback reports should give a detailed description of the situation, quoting the Hardware and Software versions used, plus the flight data records in IGC format with short time recording intervals.

The latest version of this handbook and other related documents can be found at the Website [www.flarm.com](http://www.flarm.com). This Website also has answers to Frequently Asked Questions.

This Website also carries announcements when new software versions or functions become available. If you enter your name on the mailing list, you will automatically receive notification of changes as and when they happen: [www.flarm.com/mailman/listinfo/user-list\\_flarm.com](http://www.flarm.com/mailman/listinfo/user-list_flarm.com)

To use existing devices after March 1, 2006 it is required to update the software to version 3.00 or higher. Use the free PC installation software available at [www.flarm.com](http://www.flarm.com). You need a PC with Windows 98 / ME / 2000 / XP with a serial port or a suited USB-serial converter plus a data-power cable like the one used for most IGC flight recorders. This cable connects the PC to FLARM and supplies FLARM with power. Ensure you have configured the correct PC COM-port, only use the Power/Data-port on FLARM (not the Extension-port) and know the printed device serial number. After completion of the software update, use the same PC software to load the most recent obstacle file to FLARM; this file is available on [www.flarm.com](http://www.flarm.com) as well. Then use the PC software to configure the flight recording functionality accordingly. We recommend also updating external displays as described in the installation manual. In case of questions, contact your FLARM dealer.

Note that flight recording on Hardware Version 1 won't be possible until end of March 2006.

 Software-Versions 3.x will only remain operational until the end of February 2008. After this date, you must update the device in order to use it in the air.

## **2. How it works**

FLARM receives position and movement information from an internal 16 channel GPS receiver with an external antenna. A pressure sensor<sup>1</sup> further enhances the accuracy of position measurements. The predicted flight path is calculated by FLARM and the information transmitted by radio as low-power digital burst signals at one-second intervals. Provided they are within receiving range, the signals are received by further aircraft also equipped with FLARM. The incoming signal is compared with the flight path predicted by calculation for the second aircraft. At the same time, FLARM compares the predicted flight path with known data on obstacles, including electric power lines, radio masts and cable cars.

If FLARM determines the risk of dangerous proximity to one or more aircraft or obstacles, the unit gives the pilot warning of the greatest danger at that moment. The warning is given by a whistle sound (beep) and bright light emitting diodes (LED). The display also gives indication of the threat level, plus the horizontal and vertical<sup>1</sup> bearing to the threat. During circling flight different methods of calculation are employed to those used during straight flight.

The GPS and collision information received from other aircraft can also be made available for third party equipment (e.g. external display, speech synthesizer, PDA) via a serial data output. Such equipment is available from a number of manufacturers.

---

<sup>1</sup> Requires Hardware Version 2 or higher. However, the vertical bearing on the serial data output is also available to third-party equipment on Hardware Version 1.

The operating range is very dependent upon the antenna installation in the aircraft. The normal range is about 2 km. In individual cases the range may be up to 5 km, which can be valuable for fast sailplanes with a speed of up to 250 kt, providing the pilots in both aircraft with a warning enabling visual identification and reaction to the potential hazard. Warnings are given in order of the time remaining before the potential collision, not the geometrical distance. The first warning level for another aircraft is delivered when less than 18 seconds remain to the possible collision; the second warning level is delivered when less than 13 seconds remains; the third level when less than 13 seconds remains. The warning times for obstacles are somewhat greater.

The warnings continue as long as FLARM calculates a threat of collision. The warning level may decline or be cancelled, depending upon the prediction. The warnings are selective; they are only issued if the calculation reveals a high probability of collision in the near future.

In addition, FLARM operates as an IGC-compatible flight recorder including the G-record if this software option has been configured. However, there is no intention to IGC-homologise the unit as Flight Recorder.

With the standard February 2006 obstacle databank there is memory for more than 50 hrs of flight recording at a 4s interval. Use the free PC-software to download flights to your PC and to properly configure your device for flight recording. Flight recording automatically starts when the aircraft is moving and ends when the unit is switched off. Switching off or rebooting the device during the flight results in separate flight record files. Allow at least 2 minutes (if the interval is 4s, our recommended value) after landing before you switch off the device else you lose the last part of the flight. Allow more time after landing if the interval is higher. When the memory is full, the oldest data is overwritten. Always download your flight data before you update the obstacle databank or the software.



### **3. General Advice on Operation**

This Manual must be carried on board the aircraft. When permanently installed in an aircraft, the 'AFM Supplement' must also be carried in the aircraft.

In flight the pilot must have direct sight of and immediate access to a switch or circuit breaker that disconnects FLARM from the aircraft electrical power supply, without affecting other essential aircraft systems. This might be necessary if the pilot suspects that FLARM may be interfering with another on-board system, the suspected presence of smoke, the smell of smoke, or flying in a country where the use of FLARM is not permitted.

FLARM must not be operated at night or with night vision systems.



FLARM will not operate without adequate GPS signal strength. Correct antenna installation has a great effect on the transmission/receiving range.

Installation and operation must be on the basis of non-interference with and no hazard to the existing suite of other certified equipment necessary for safe flying operation, or installed to comply with official requirements. Installation and operation must comply with official regulations and requirements. It is recommended that the FLARM, GPS and radio antennae are all installed as far away as practicable - but at least 25 cm from - susceptible aircraft systems such as GPS antennae and the magnetic compass.



The unit must be protected from solid particles or liquids, should not be exposed in use to temperatures below -10°C or above +60 °C , or stored at temperatures -20°C or above +70 °C, because this may cause irreparable damage. On the ground, the unit should be protected from exposure to long periods of direct sunlight, because it is likely to be overheated.



Details on correct installation will be found in the Installation Manual.

## 4. Operating Modes

FLARM operates in two modes, *Nearest* and *Collision*. The change from one mode to the other is effected by a two-second push on a button followed by a brief visual confirmation from the unit. After the change has been signalled, the current mode selected is not displayed. When switched on, the unit is in *Nearest* mode.

 The warnings given are identical in both modes, and generally relate to an immediate threat to which the pilot should make an immediate and appropriate reaction. The assumption has been made that following a warning it will take up to 12.5 seconds from the time that the other aircraft is seen, until a change in flight path has removed the threat<sup>2</sup>.

When operating in the *Nearest* mode, the unit also reports the presence of other aircraft operating in the vicinity, even though calculations indicate that they do not represent a threat. The information displayed is limited to a radius of two kilometres and a vertical separation of 500 m. Only one single aircraft is indicated, with Hardware Version 3 or later in green. The optical signal is static (no flashing); the threat intensity is not indicated and there is no sound warning. As soon as FLARM detects the risk of a collision it automatically switches to *Collision* mode, followed by automatic reversion to *Nearest*. The choice of mode is presented, such that immediately after pressing the key, the display presents a diverging pattern (Hardware Version 1 and 2:  ; version 3: ).

When operating in the *Warning* mode a red LED lights up only if the calculation predicts a threat. Warnings are always shown by flashing LEDs, the threat level being shown by the number of LEDs illuminated, by the frequency of flashes, and the simultaneous sound signal (beep). Selection of this mode is indicated by a upwards converging pattern (Hardware Version 1 and 2:  ; Version 3:  ) immediately after pressing the selector key.

In both modes the pilot can **suppress the display and the acoustic warning**: after a double push FLARM will suppress all visual and acoustic signals relating to traffic, obstacles or other threats. The act of selecting suppression is followed by a descending tone. A further double-push reinstates the *Collision* mode at once and is followed by a rising tone. While warnings are suppressed, FLARM nevertheless continues to transmit signals for reception by other aircraft.

## 5. Front Panel

The dark grey front panel of Hardware Versions 1 and 2 has a push-button, four green Status-LEDs, ten red collision warning LEDs and four red LEDs for vertical<sup>1</sup> position indication.

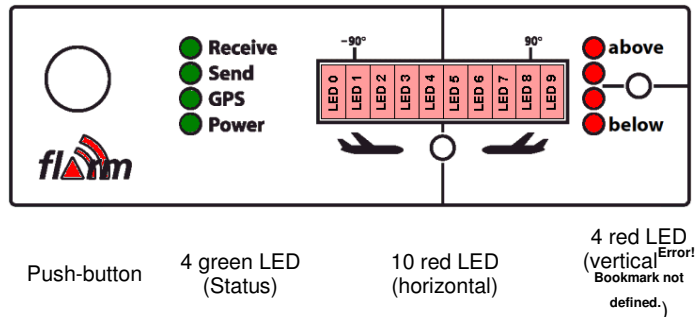

The front panel of Hardware Version 3 has a push-button, four green Status-LED, twelve bicolour LED for horizontal and four bicolour LED for vertical position indication. Depending on the threat caused by other aircraft or obstacles the LED show up red or green. Also included is a microSD-reader which can be optionally used at a later stage for updates and downloads.

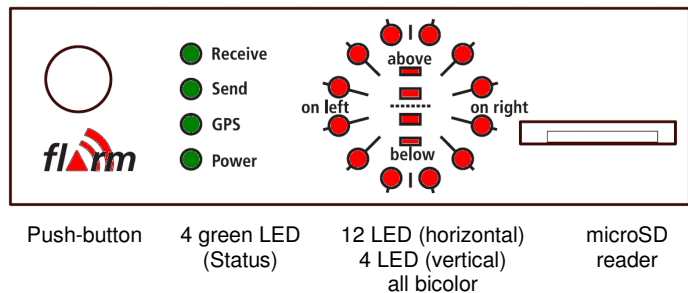

<sup>2</sup> These times were published in 1983 FAA Advisory Circular 90-48-C and were based on military data. They relate to fast jet pilots with no on-board warning systems for other traffic and hazards. The assumption was made that only one aircraft takes avoiding action. Of the 12.5 seconds, five seconds were to recognise the threat of collision and four seconds were required to decide upon avoiding action. No information is available as to whether these times are applicable to light aircraft, sailplanes or helicopters, when using a warning system.

**6. Start-Up**

FLARM is always switched on if the unit is connected to an adequate power supply.

Immediately after it has been switched on there follows a one-second long beep while a start-up pattern might be shown on the LED, followed by a binary presentation of the Hardware-Version installed during the system self-test. The self-test mode lasts from two to 20 seconds, depending upon the size of the obstacle data bank. The February 2006 data bank takes about twelve seconds.

- 0x01 Hardware Version 1 (only red)
- 0x02 Hardware Version 2 (only red)
- 0x03 Hardware Version 3 (only green)

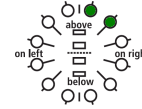

This is followed by another one-second beep, followed by a brief binary presentation of the Software-Version:

- Hardware Versions 1 and 2: LED0 to LED3 represent the major versions, LED4 to LED9 the minor versions. Everything is shown in red.
- Hardware Version 3 and later: The first six LEDs clockwise represent the minor version in red, the other LEDs clockwise the major version in green.

If the Software Version is not indicated and the beep sound is not emitted, the unit is not ready for operation.

- 0x04A Software Version 1.10 (operational only to April 2005)
- 0x081 Software Version 2.01 (operational only to Feb. 2006)
- 0x0C0 Software Version 3.00 (operational only to Feb. 2008)
- 0x0C1 Software Version 3.01 (operational only to Feb. 2008)
- 0x0CD Software Version 3.13 (operational only to Feb. 2008)
- 0x100 Software Version 4.00 (available from Feb. 2008 verfügbar)

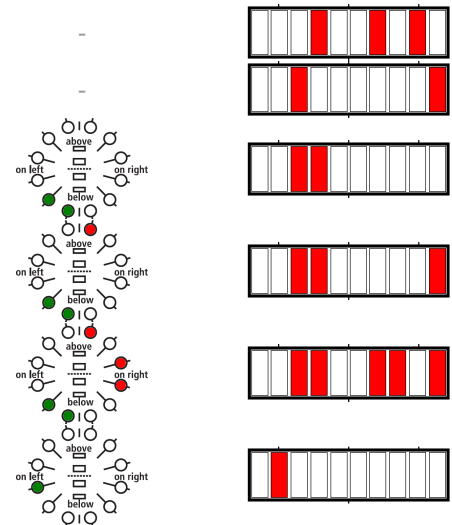

Then FLARM shifts to normal operation and waits until it has acquired an adequate GPS position fix. When switching on, this procedure can take *several minutes*. Without a proper GPS position fix, the unit is not ready for operation. Before departure the pilot must ensure that at least the Power-, GPS- and Send-LED are all continuously on.

## 7. Fault Finding

If a fault should occur during start-up self-test or subsequent operation, then all four green status LEDs will flash in unison for 30 seconds, while the red collision LEDs will give a binary indication of the most serious fault. The fault display can be stopped before 30 seconds has elapsed by pushing the button.

For safety reasons FLARM will not start up if there is a fault. FLARM may not be used if a fault has been reported or indicated. Limited operation is possible if there is an indication of a problem with the obstacle data bank or data recorder.



0x11	Fault: Software out of date (needs GPS reception)	<i>No operation</i>	
0x21	Fault: Low Voltage	<i>No operation</i>	
0x31	Fault: Internal GPS communication	<i>No operation</i>	
0x32	Fault: Faulty GPS configuration	<i>No operation</i>	
0x41	Fault: Internal radio communication	<i>No operation</i>	
0x51	Fault: General internal communication	<i>No operation</i>	
0x61	Fault: Flash memory	<i>No operation</i>	
0x71	Fault: Pressure sensor	<i>No operation</i>	
0xF1	Fault: Other fault	<i>No operation</i>	
0x81	Indication: No obstacle data bank	Operation possible	
0x91	Indication: Flight recording not possible	Operation possible	

The communications faults itemised above indicate if internal modules within FLARM are not communicating correctly with each other. For reasons associated with the system, reduced radio range cannot be detected by a single unit alone.



Software-Versions 3.x will only operate until the end of February 2008. After this date, you must update the device in order to use it in the air. On publication the update will have no functional changes and can be downloaded free of charge. Users will be able to load the software with the aid of a suitable power supply/data cable (not supplied). This operation requires the user to have the unit Serial Number to hand. Software validity has to be time-limited to ensure that all FLARM units are mutually compatible and that updates include the latest obstacle data.

## **8. Status-Display**

The green Status Display LEDs operate as follows; normal operating mode is underlined:

- **Receive:** Lights up when a signal is detected from another aircraft less than 2 km away, with a height separation of less than 500 m; otherwise the LED is dark. If the warning is temporarily suppressed (see below) but signals are still received from other aircraft, then the LED flashes.
- **Send:** Lights constantly during operation and indicates that the on-board FLARM is transmitting. Transmission requires GPS reception.
- **GPS:** Lights constantly during operation (with very brief interruptions once per second). If the LED is constantly dark and flashes briefly once per second, then there is no GPS reception. When switching on this condition can take several minutes.
- **Power:** Lights constantly during operation. If the LED flashes, then the power supply has dropped below 8 V. FLARM will not operate below 8 V DC.

The 'Receive' and 'Send' LEDs give no indication of FLARM's transceiver range.

## **9. Push Button<sup>3</sup>**

The push button can be used to select the following functions:

- **Brief Push** (<0.8 s) changes the volume from *<loud>* to *<medium>* to *<quiet>* to *<silent>* (and *<loud>* again). A short sound is emitted at the new volume selected. The default setting is *<loud>*.
- **Longer Push** (2 s) changes mode between *<Nearest>* and *<Collision>*. Visual confirmation. Default setting *<Nearest>*.
- **Double Push** suppresses optical and acoustic warnings for five minutes. Suppression is followed by declining note, normal setting followed by a rising note. A double push terminates the suppressed operation at once.
- **Long Push** (>8 s): Re-boot. This procedure is recommended if a fault is apparent. No confirmatory sound signal.
- **Very long push** (>20 s) brings FLARM back to the factory settings. The very long push deletes all configurations that have been loaded by the user. No confirmatory sound signal.

---

<sup>3</sup> Activate the external display update by pushing the button four times in rapid succession. For details see the Installation Manual.

## 10. Aircraft Anti-Collision Warnings

An illuminated red LED indicates the approximate bearing to an aircraft currently posing the biggest threat of collision. The bearing is *relative to the track*. This indication is inaccurate if there is a strong wind, if the aircraft is in a sideways yaw, or if ground speed is very low (e.g. when a helicopter is in the hover). The display is refreshed every second.

The unit emits an audio warning (beep) tone at the same time as the flashing red optical warning. The time between the warning and possible collision is brief, just a few seconds. Warnings of fixed obstacles are given slightly earlier.

### Horizontal bearing indicated on Hardware Versions 1 and 2

Each red LED is allocated to a sector of sky around the aircraft horizontal plane in a side view. The aircraft centreline is indicated by a white line above and below the mid point (between LED4 and LED5). A short white line is located above LED1 and LED8, marking 90° left and right.

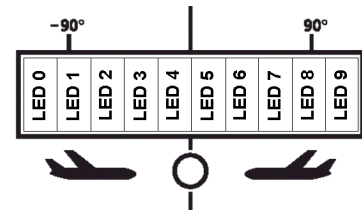

- LED 0      ~210°   quadrant rear left
- LED 1      270°   hard left 9 o'clock
- LED 2      296°   left 10 o'clock
- LED 3      321°   left 10-11 o'clock
- LED 4      347°   front left 11-12 o'clock
- LED 5      13°   front right 12-1 o'clock
- LED 6      39°   right 1-2 o'clock
- LED 7      64°   right 2 o'clock
- LED 8      90°   hard right 3 o'clock
- LED 9      ~150°   quadrant rear right

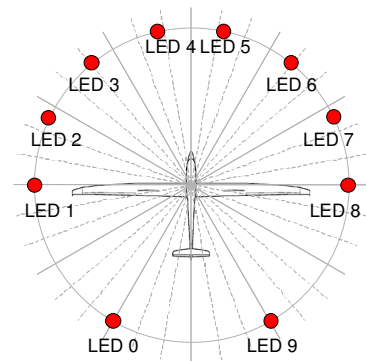

### Horizontal bearing indicated on Hardware Version 3 and later

The twelve bicolour LED show a compass rose, i.e. the birds view on the traffic situation. 'Top' is track-up according the own aircraft. Each LED covers an equal-sized horizontal sector of 30°.

### Danger from the front or side

If the threat of collision with another aircraft is from the front or side, but not from the rear, then the threat level will be flagged up by the display. If the threat is moderate (less than 18 seconds to possible collision), a single LED lights up; in the case of a medium threat (less than 13 seconds) then two diodes light up; if the threat is imminent (less than 8 seconds) three LEDs. The threat is at the centre of the illuminated block. The flash frequency increases with the threat.

Moderate threat from ca. 3 o'clock  
(less than 18 seconds to calculated collision)

Slow flash at 2Hz



Moderate threat from 1 to 2 o'clock  
(less than 18 seconds)

Slow flash at 2Hz

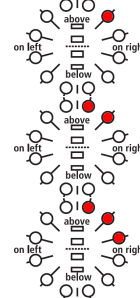

Medium threat from 1 o'clock  
(less than 13 seconds)

Medium flash at 4Hz

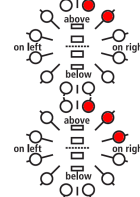

Immediate threat from 1 to 2 o'clock  
(less than 8 seconds)

Rapid flash at 6Hz

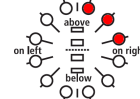

**Danger from the rear**

If the threat is from behind, then the threat level on Hardware Version 1 and 2 is given only by the frequency of LED flashes, not the number of LEDs activated.

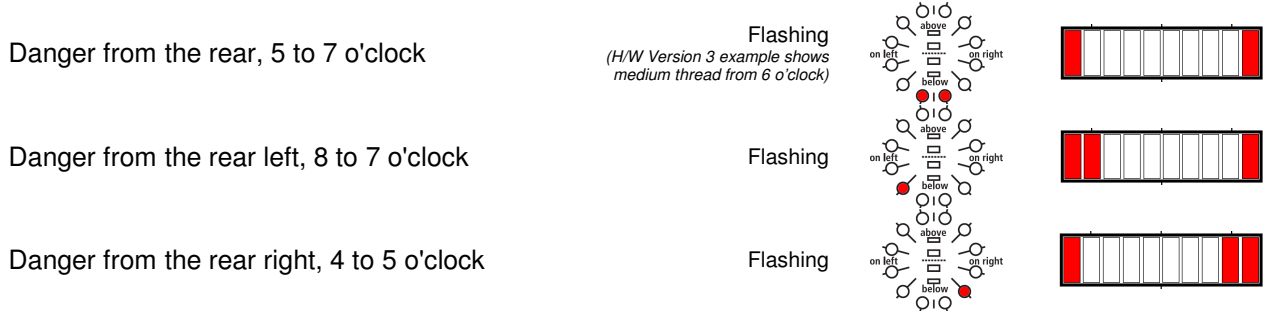

**Vertical indication**

The vertical bearing is indicated by a vertical<sup>1</sup> line of four red LEDs and show the relative bearing to the flight level, not the aircraft altitude. The uppermost or lowest LEDs illuminate when the bearing exceeds 14°. The LED flash frequency is identical and synchronous with that of the horizontal display.



**Traffic indication (only in Nearest-mode)**

In Nearest-mode the closest aircraft is shown as long as no warning is necessary. Traffic indications don't flash, there is no sound and the distance is not shown. Hardware Version 3 and higher show traffic indications in green.

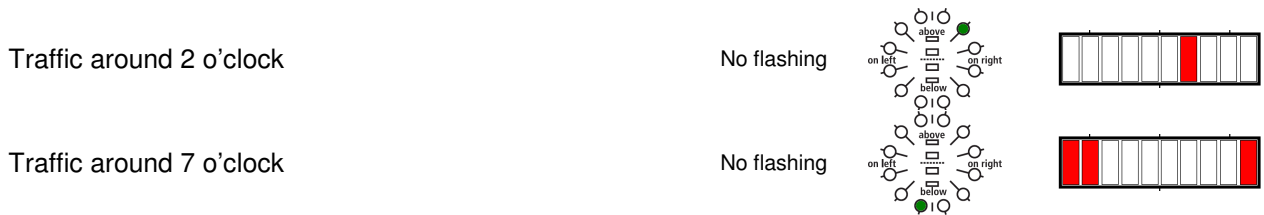

## **11. Obstacle Warnings**

The standard obstacle data bank (as of February 2006) has about 33,000 coordinates locating about 11,000 Alpine obstacles<sup>4</sup>. This data bank is loaded by FLARM at manufacture; subsequently the user may upload but not alter up-dated information via a PC. Special data banks, corrections and amendments can be reported to us.

The FLARM display flashes when there is warning of obstacles. The warning always relates to obstacles straight in-line with the current flight heading. In other words there is no horizontal or vertical bearing given to the obstacle. The threat level depends upon the time remaining to impact; the flash frequency increases with reducing distance from the obstacle. The display is refreshed every second.

A warning is given if an aircraft flies under a cable or power line.

An acoustic warning (beep) is given at the same time as the flashing fixed obstacle warning. The time between warning and possible collision is brief, just a few seconds. However, warnings are given of fixed obstacles earlier than those for other aircraft.

Hardware Versions 1 and 2 show obstacles as follows:

- Moderate threat  
(less than 28 seconds to calculated collision)
- Medium threat  
(less than 19 seconds)
- Immediate threat  
(less than 10 seconds)

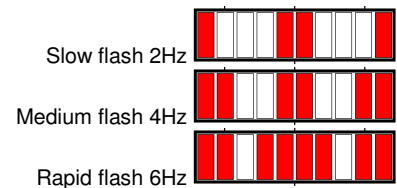

Hardware Versions 3 and later show obstacles as follows:

Toggle while the toggle frequency depends on the thread.

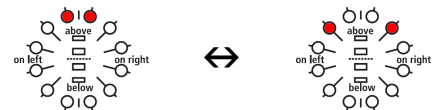

---

<sup>4</sup> Sources: FOCA (Switzerland, January 2004; Data interpolated), Austrocontrol (Austria, January 2005), Land Tirol (Austria, February 2005), Land Vorarlberg (Austria, February 2005), Deutsche Flugsicherung / Amt für Flugsicherung der Bundeswehr (Germany, January 2006), 3rd party data collection (French Alps, February 2006), CIGA-ANOV (parts of Italian Alps, May 2005). Single antennae out of Switzerland and Austria are not part of the data bank. Neither FLARM Technology nor these organisations accept any responsibility for the accuracy, fullness or up-to-date status of this data. The processes employed to generate the data bank have not been certified in accordance with EUROCAE ED-76 / RTCA DO-200A ('Standards for Processing Aeronautical Data', September 28, 1998).

## 12. Operating Limitations



FLARM is designed and built as a non-essential 'situation awareness only' unit to support the pilot, and cannot always provide reliable warnings. In particular, FLARM does not give any guidance on avoiding action. Under no circumstances should a pilot or crewmember adopt different tactics or deviate from the normal principles of safe airmanship. The use of FLARM is solely at the discretion of the commander and his delegated crew member. Operation must be preceded by thorough familiarisation by the commander or his delegated crew member with the Operating Manual.

FLARM will only give warnings of other aircraft that are likewise equipped with a compatible unit. FLARM does *not* communicate with Mode A/C/S transponders and is not detected by ACAS/TCAS/TPAS or Air Traffic Control. Likewise FLARM does not communicate with FIS-B, TIS-B or ADS-B.

Compatible FLARM units must be within range in order to provide a warning. The range is very much determined by the type, installation and position of the radio antennae, plus the relative positions of the two aircraft. Under *optimum* conditions the internal antennae can give a head-on range of up to 5 km; normally, range is about 2 km, which is adequate for light aircraft and sailplanes. The radio signals can only be received by *line of sight*. There is no FLARM signal between two aircraft on opposite sides of the same mountain.

FLARM has to know its *current* position in order to operate. For this reason, FLARM will only operate in the presence of good quality three-dimensional GPS reception. GPS reception is greatly influenced by the installation and position of the antenna, and aircraft attitude. This is particularly true during turns, when flying close to mountain slopes and in areas known for poor reception. If the installation is poor the GPS signal quality may be reduced. In particular, there can be rapid degradation of height calculations. FLARM resumes operation as soon as the GPS reception quality is adequate.

Movements calculated by the GPS relate to a fixed system of *terrestrial* coordinates. In strong wind there may be a substantial difference between aircraft heading and track, leading to a distortion of the threat bearing. If the wind speed is one third of True Airspeed (TAS) and the yaw-free aircraft Heading is 90° out of wind, then the threat indication displayed has an error of about 18°. If the wind is very strong, the Track can deviate up to 180° from Heading. Under such circumstances and when circling, the calculation and warnings given are unusable.

When close up, when two aircraft are at the same or similar height, or GPS reception is poor, the vertical bearing indication is imprecise and fluctuates.

FLARM calculates the predicted flight path of the aircraft to which it is fitted for less than the next 30 seconds. This prediction is based on immediate past data, current position- and movement data, plus a movement prediction model that is *optimised for the respective user*. This forecast is associated with a number of uncertainties that increase with an extension of the forecast time. There is no guarantee that an aircraft will actually follow the predicted flight path. For this reason, the warning issued will not be accurate in all cases. In sport flying flight path predictions of more than 30 seconds are *unusable*. This is particularly true for sailplanes and hang gliders. For this reason, the radio range is generally adequate.

Warnings are given at very short notice, i.e. the warning is given within a time frame of from a few seconds to 30 seconds, depending upon the closest predicted proximity, as calculated. The threat intensity (pitch of the warning tone, LED block width, flash interval) flags up the threat (collision time point), but not the geometric distance. FLARM only issues a warning if the calculation forecasts a *considerable* threat. For this reason, it is usual - depending upon the mode selected - that no warning is given about the presence of other aircraft, in spite of the fact that signals have been correctly received.

When a number of moving threats or fixed objects are within range, then FLARM gives warning *only* of the most dangerous in accordance with the threat calculation algorithm. The pilot is unable to confirm receipt of this warning, nor is he able to call for presentation of further threats. In spite of the warning issued for one other aircraft or fixed objects, it is quite possible that there are several further aircraft or fixed objects that represent a greater threat than that which has been signalled. When the unit simultaneously detects a threat from moving and fixed obstacles, then the warning issued relates to the earliest likely collision.

FLARM indicates the rough position of the aircraft or obstacle that currently represents the biggest threat, in accordance with the algorithmic calculation; FLARM Hardware Version 2 (and onwards) also displays a vertical bearing. In the case of fixed obstacles, the unit does not signal a bearing. FLARM does not indicate where the closest proximity may occur, nor does it signal avoiding action. Whether and how avoiding action is taken is solely a matter for the pilot, who must base his decision on his own observation of the airspace. In taking his decision, he must comply with the Rules of The Air and ensure that no additional hazard is caused by his action. Depending upon the phase of the flight, FLARM uses different forecasting methods, movement models and warning calculations, to provide the pilot with the best possible support without causing a distraction. For example, when a sailplane is circling, the system sensitivity is reduced. These models and processes have been optimised, but are nevertheless a compromise. As seen by the pilot these models are the source of 'false alarms'; i.e. FLARM would give warnings of 'threats' that would not subjectively be regarded as a real danger. It is quite possible that FLARM will not give warning of the highest threat, or will give any warning at all.

Obstacle warnings (e.g. cables, antenna masts, cable cars, avalanche dynamite wires, power lines) are dependent on the information having been stored *correctly* in the internal data bank. The unit cannot give warning of any fixed object that has either been incorrectly stored, or not stored at all. No data bank is complete, up-to-date and correct. Obstacle information stored has usually been simplified; for example, FLARM assumes that a power wire is slung absolutely straight between two fixed points with no sag. Likewise, data for power lines does not include all intermediate masts. In addition, FLARM data does not include terrain data and no such warnings are possible.

FLARM radio communications take place in a license-free band in which there is general freedom to transmit and receive. This means that the band is also available to a number of other uncoordinated users. FLARM has no exclusive right to the use of this band and there is no guarantee that FLARM will not be subject to interference by third parties.

There are national differences in frequency allocation and operating conditions between countries. The aircraft commander and user are solely responsible for ensuring that their use of FLARM conforms with local regulations. No radio licence is required for FLARM in Switzerland.

The radio transmission protocol employed places *no limit* on the number of units that may be operated within a given range. However, an increasing number of units within range is associated with a reduction in the probability that a single coded signal will be received ('graceful degradation'). The probability is small that subsequent signals will not be received from the same transmitter. FLARM is designed to receive and process signals from up to 50 aircraft within range. A high number of FLARM units within range has no effect on range.

The transmitter has ***no effect*** on what the receiver in the other aircraft does with the data. It is possible that this data may be captured and stored by other aircraft, or by ground stations, or used for other purposes. This opens up a range of possibilities, some of which may be in the pilot's own interest, (e.g. automated generation of an sailplane launch logging system, aircraft tracking, last position recovery), while others may not be (e.g. detecting tailing of other aircraft, airspace infringements, failure to take avoiding action prior to a collision). When FLARM makes a transmission, the signal also bears identification. The user can -- even though this is not recommended -- configure the unit so that identification is generated randomly and alters at one-minute intervals, making a back-trace difficult.

Operation of FLARM is limited to non-commercial day VFR flights. FLARM may not be used for navigational purposes or aerobatics.

At present FLARM has not been certified or tested in line with the usual aviation procedures (e.g. DO-160E). The FLARM software development is *roughly* in-line with Level E of DO-178B; i.e. a partial or total failure of FLARM will have no effect upon the safe operation of the aircraft, nor does it increase crew workload.

Until further notice FLARM may not be used in the USA or Canada without written authority of FLARM Technology, or in aircraft that is registered and/or insured in the USA or Canada. Likewise, operation of FLARM is forbidden in aircraft in which one or more of the occupants resides in or is a citizen of the USA or Canada. Likewise, use of FLARM is forbidden if the aircraft concerned takes off from, makes an intermediate or final landing in the USA or Canada.

FLARM Technology its associates, development team, suppliers, manufacturers and data suppliers accept no responsibility for any damage or claims that may arise from use of FLARM.